



# Technical and Installation manual

## All Models

*For owners, installers and service engineers*



## Important Health and Safety Information for Installers and Service Engineers

Health and Safety at Work Act 1974

Consumer Protection Act 1987

COSHH Regulations 1988

The following information is given as a requirement of the above legislation.

Great care is taken by GAH (HEATING PRODUCTS) LIMITED to ensure that GAH Coldstream systems are designed and manufactured to meet general safety requirements when properly used and installed as recommended in this manual.

It is the responsibility of Users and Engineers to ensure that adequate protective clothing and glasses are worn when working with the GAH Coldstream system.

### SEALS AND INSULATION

Insulation and sealing materials are used in the construction of the GAH Coldstream cylinders. Units are sealed and when used in the manner for which they are intended the insulating and sealing materials do not present any known hazard.

However always observe the following recommendations:-

1. Avoid inhalation of fibres or dust, wear face mask.
2. Avoid eye contamination by fibres or dust - wear eye protection.
3. As far as possible avoid any skin contact with Fibreglass Insulation, Glass Rope, Mineral Wool, Insulation Pads and Ceramic Fibre.

### OTHER MATERIALS

#### SEALANTS, ADHESIVES AND PAINTS

Sealants, Adhesives and Paints are used in the construction of the GAH Coldstream components. When used in the manner for which they are intended they do not present any known hazard.

### ELECTRIC

GAH Coldstream has no electrical connections.

***GAH (HEATING PRODUCTS) LIMITED will not accept responsibility for any damage or personal injury caused by not giving due consideration to the above safety recommendations.***

In pursuance of a policy of constant development, GAH (HEATING PRODUCTS) LIMITED reserve the right to change any boiler part or design without notice, therefore certain details included in this manual may not be correct at the time of printing. Any modification and improvements detailed in this manual does not commit GAH to update any system previously supplied.

Manual Part No. .... 015-15011  
Manual Ref. .... CS10  
Issue ..... 5  
Date ..... Feb 2010

© 2010 GAH (HEATING PRODUCTS) LIMITED  
GAH Coldstream and Dualstream are Trademarks of GAH (HEATING PRODUCTS) LTD.

HTS REF /GAH COLDSTREAM 10/02/10

Manual by Harber Technical Services Tel/Fax 01263 515444  
E-mail: info@harbertech.co.uk www.harbertech.co.uk

### GAH (HEATING PRODUCTS) LTD.

Building 846,  
Bentwaters Parks,  
Rendlesham,  
Woodbridge,  
Suffolk IP12 2TW

Tel: 01394 421160

Fax: 01394 421170

e-mail: mail@gah.co.uk

www.gah.co.uk

**CONTENTS**

**Section 1 Introduction**

1-1 Introduction .....	2
1-2 System Layouts .....	4
1-3 Shut Off Valves .....	9
1-4 Specifications .....	10
1-5 Larger Systems .....	11

**Section 2 Installation**

2-1 Building Control .....	12
2-2 Parts Supplied .....	12
2-3 Installation .....	13

**Section 3 Commissioning**

3-1 Commissioning Checks .....	15
3-2 Handing Over .....	15
3-3 Routine Inspection .....	15

**Section 4 Fault Finding**

4-1 Fault Finding .....	16
-------------------------	----

**1 INTRODUCTION**

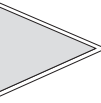

**2 INSTALLATION**

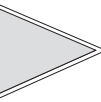

**3 COMMISSIONING**

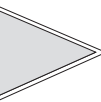

**4 FAULT FINDING**

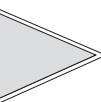

**IMPORTANT**  
**BEFORE STARTING THE INSTALLATION OF THE GAH COLDSTREAM CHECK ALL COMPONENTS**  
**HAVE BEEN DELIVERED AND ARE IN SATISFACTORY CONDITION.**

**1-1 Introduction**

GAH Coldstream is a Trademark of GAH (HEATING PRODUCTS) LTD.

**This Handbook has been compiled to assist in the Installation and Operation of GAH (HEATING PRODUCTS) LIMITED Coldstream cold water system.**

*Please Ignore 'Installation and Operating Instructions ref. 620-0027C' supplied with Accumulator.*

© 2010 GAH (HEATING PRODUCTS) LIMITED

**IMPORTANT**

**After installation the Installer of the system should give full operating instructions to the householder for the GAH Coldstream System.**

*Note*

*For components supplied with standard systems refer to page 14.*

*Note*

*Other alternative installations are available to suit specific site requirements.*

**1-1.1 The GAH Coldstream System**

The GAH Coldstream systems by GAH Heating Products have been developed as an advanced solution for domestic hot and cold water installations. A GAH Coldstream system will increase the water volume and maintain the mains pressure to both the hot and cold supplies when more than one outlet is in use at the same time.

GAH Coldstream has been designed to function on the minimum standard for domestic water supply as provided by local water authorities - which is 1 Bar at 9 litres per minute at boundary.

GAH Coldstream Accumulators can also be utilised to increase the flow rates to unvented cylinders, combination boilers, heat exchangers, electric showers and other mains fed applications.

GAH offer full technical assistance and design service to enable the optimum GAH Coldstream system to be configured to overcome situations where poor mains supply and pressure are considered a problem.

**1-1.2 How the GAH Coldstream System Works**

The system mainly comprises an Accumulator (cold water storage vessel).

The Accumulator has an internal controlled butyl diaphragm, incoming cold water is stored within this diaphragm at mains pressure. The air space between the diaphragm and the Accumulator case is pressurised, this balances the supply and maintains pressure to an unvented cylinder or mains pressure appliance and cold outlets. When hot and cold water outlets are turned on, the stored water from the Accumulator supplements water from the incoming mains, this results in consistent pressure and flow to all taps, showers and baths when outlets are used simultaneously. Pressure will be sustained as long as the Accumulator is of adequate size and is holding sufficient volume of water.

More than one Accumulator can be linked together to satisfy greater demand.

**1-1.3 GAH Coldstream System Features**

1. All taps and showers are at the maximum incoming mains pressure.
2. Provides increased water flow rate to both hot and cold water outlets.
3. Suitable for properties with very low mains flow rates (9 litres per minute).
4. Suitable for properties with small bore (15mm) mains feed.
5. Balanced Hot and Cold water supply pressures.
6. Minimal pressure drop when more than one tap is in use.
7. No loft storage tank - no risk of water stagnation.
8. Completely sealed system, low risk of Legionella.
9. Wholesome water to all cold taps.
10. No tank filling noise.
11. GAH Coldstream utilises GREEN TECHNOLOGY, no electrics or wasted energy.

*Note*

*\*Subject to boiler manufacturers flow restrictions.*

**1-1.4 GAH Coldstream Application**

The GAH Coldstream range of Accumulators from GAH Heating Products has been designed for installation on mains fed systems, to provide increased flow rates and stabilize pressure problems. When installed on a main supply feeding a \*Combination Boiler, it will ensure maximum flow rate through the boiler when other outlets are turned on, and stop pressure fluctuations provided the Accumulator and pipework is sized correctly. Although the performance will be greatly improved, you cannot improve on the combination boilers maximum given hot water output. When installed on existing unvented systems you create the Dualstream principle and maximise the cylinders performance and that of the balanced cold supplies, by increasing the volume through the Accumulator. The larger the Accumulator the longer the performance can be maintained. Other factors need to be considered when sizing or choosing the Accumulator model.

**GAH strongly recommend that pressure and flow readings are undertaken to establish whether there is a flow rate or pressure problem.** The Accumulator can be installed anywhere on the main supply entering the property, basement, utility, loft etc. and there must be a check valve installed on the main supply and 3.5 Bar pressure reducing valve if the pressure is likely to rise above 5 Bar. The air charge in the Accumulator is factory set at 2 Bar but may require adjusting so that it is between 1 - 1.5 Bar below the mains pressure minimum vessel pressure 0.5 - 0.8 Bar, (consult GAH if lowering to this pressure) to allow water to enter the vessel. The lower the mains pressure the less water that can be stored in the Accumulator, so always remember to oversize the Accumulator by at least one or two sizes larger than the unvented cylinder or flow rate requirements.

GAH offer a full design service and technical assistance and work closely with companies to resolve situations regarding poor main supplies and volume problems.

For larger installations and future projects, GAH offer the Dualstream system which combines both an Accumulator and an unvented hot water cylinder for a complete hot and cold water system.

*Note*

*For further information on GAH Dualstream consult GAH Heating Products.*

**1-1.5 GAH Dualstream System**

The Dualstream system utilises an Accumulator, which has a controlled butyl diaphragm that stores cold mains water at mains pressure and a range of stainless steel unvented cylinders. When a tap or shower is turned on the Accumulator enhances the main supply and helps maintain the pressure to all hot and cold outlets regardless of the flow

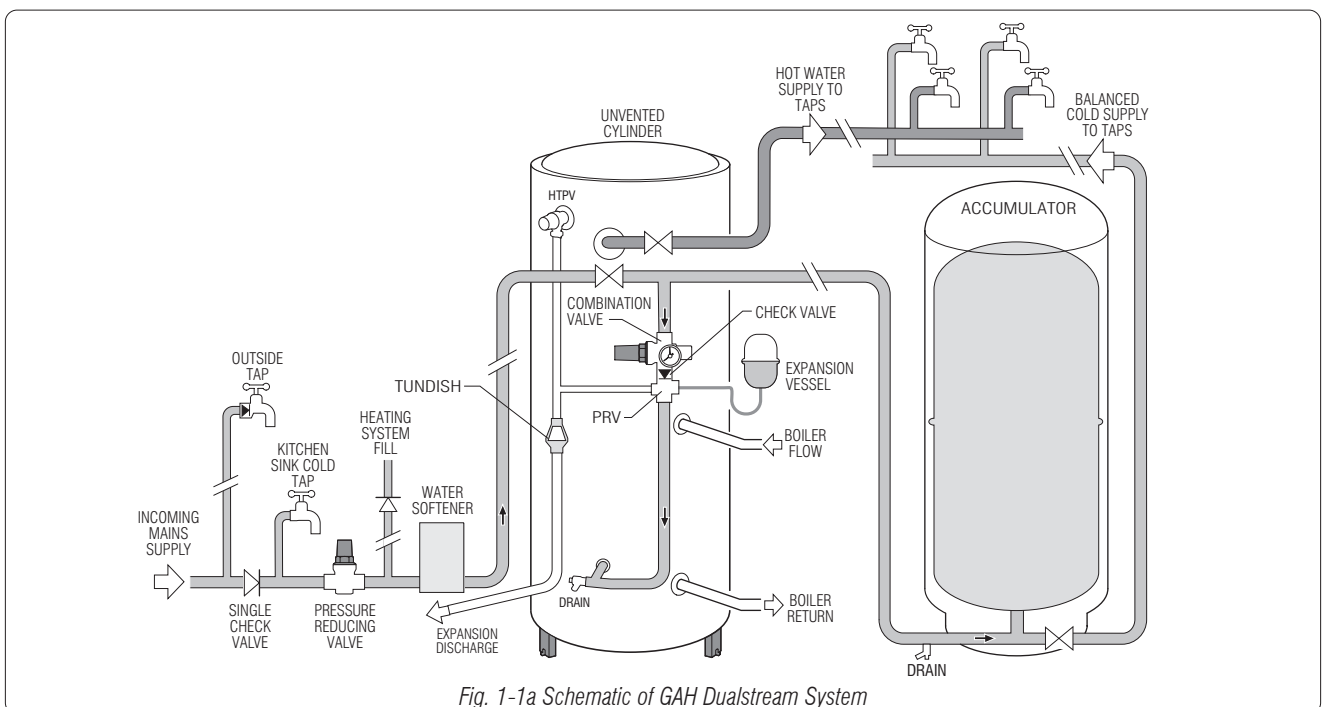

Fig. 1-1a Schematic of GAH Dualstream System

rate on the incoming main supply enabling more than one outlet to be run at the same time giving better pressures and greater flow rates at taps, showers and baths. This makes the system ideal for properties with poor mains supplies or multi-bathroom outlets. With sizes from 125 litres to 500 litres and twin coil cylinders from 210-300, Dualstream systems can be designed to suit most applications.

### 1-1.6 Central Heating System

The GAH Coldstream system does not affect the central heating installation.

### 1-1.7 Servicing

It is recommended that the system is inspected by an approved engineer once per year.

## 1-2 System Layouts

### 1-2.1 System for Small Flat

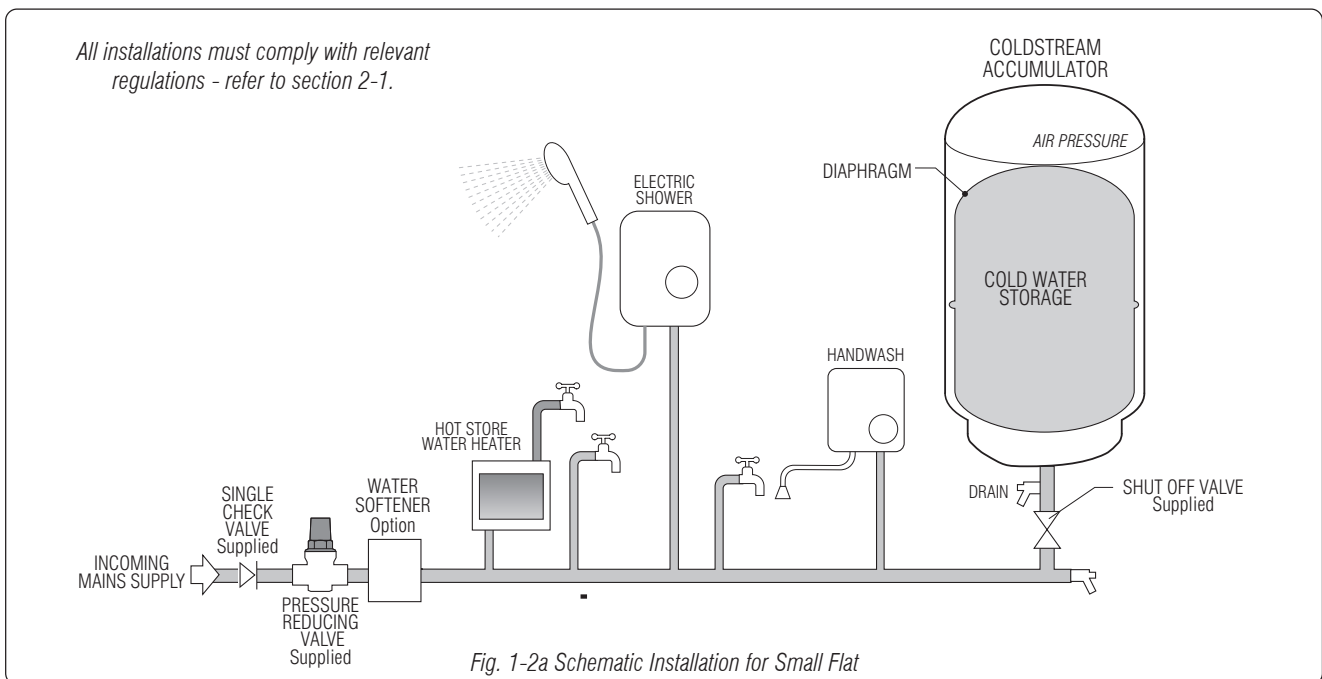

Fig. 1-2a shows typical simple configuration of a GAH Coldstream system for a small flat.

GAH Coldstream can be fitted to existing systems including systems with electric showers and water heaters providing all criteria as specified in this manual are met.

Where the accumulator is connected to the system is not critical, however having the connection further away from the incoming mains supply will significantly improve performance.

A Pressure Reducing Valve is supplied, this must be installed in the correct position, failure to comply will invalidate warranty.

A Single Check Valve is supplied, if one is not already fitted, this should be fitted to the mains supply prior to any connections or take offs to prevent back flow and to maintain accumulator pressure.

One full bore lever valve is supplied, it is recommended to install this on the supply from the accumulator.

Other shut off valves may be required depending on installation. Drain offs should be fitted to enable the accumulator and system to be fully drained. Provision must also be made for boiler/heating system fill and water softener when applicable.



**IMPORTANT**  
**The air charge pressure of the accumulator has to be adjusted before the system is filled - see 2-3.2.**

1-2.2 Existing Unvented System

All installations must comply with relevant regulations - refer to section 2-1.

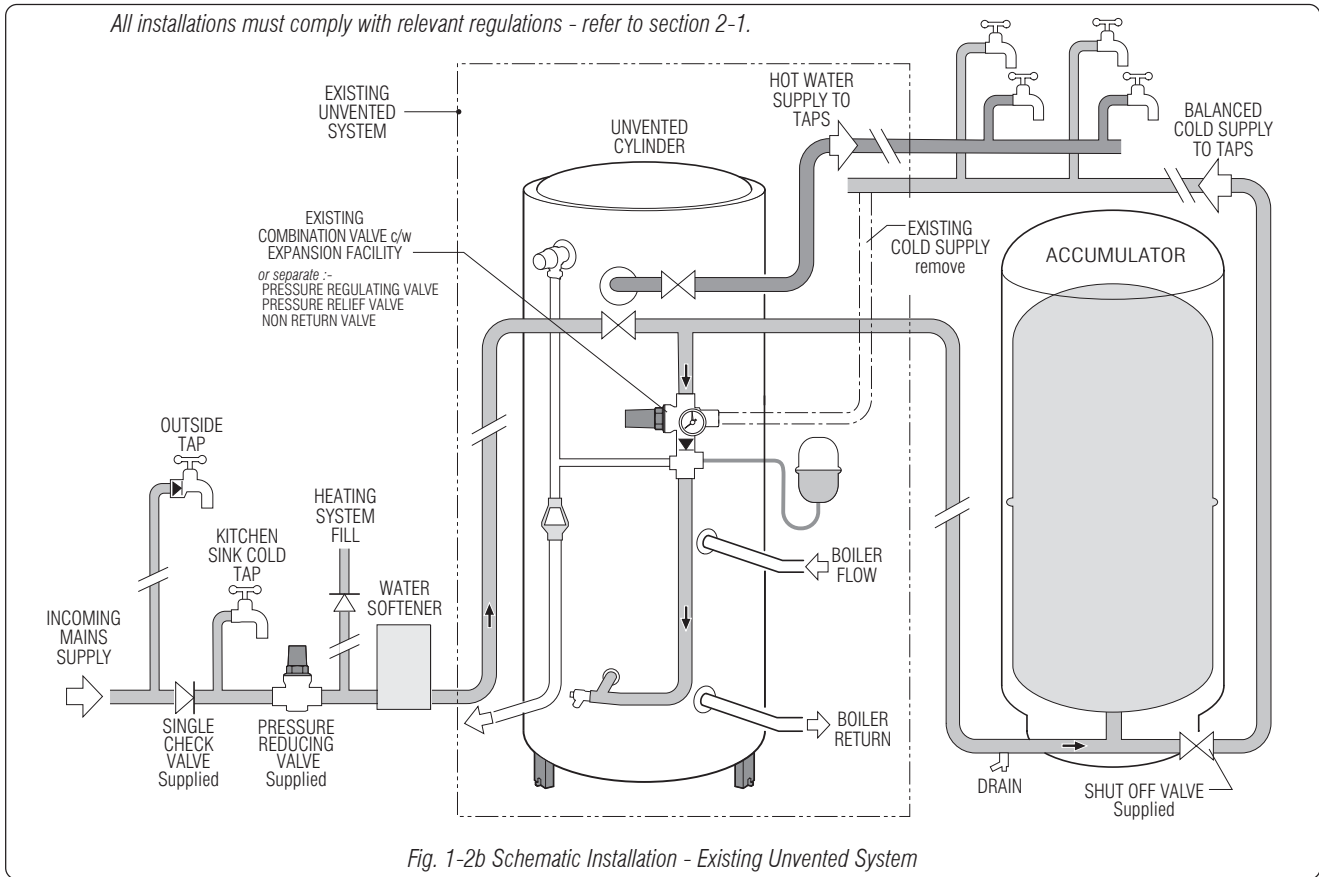

Fig. 1-2b Schematic Installation - Existing Unvented System

GAH Coldstream can be fitted to existing unvented systems providing all criteria as specified in this manual are met.

Fig. 1-2b shows typical configuration of a GAH Coldstream accumulator connected to an existing unvented indirect cylinder.

Where the accumulator is connected to the system is not critical, however having the connection further away from the incoming mains supply and down line from the cylinder take off will significantly improve performance.

A Single Check Valve is supplied with the GAH Coldstream system, if one is not already fitted, this should be fitted to the mains supply prior to any connections or take offs to prevent back flow and to maintain accumulator pressure.

A Pressure Reducing Valve is supplied, this must be installed to limit the incoming main pressure. To maintain maximum main pressure to the kitchen tap and outside taps, it can be fitted following these draw offs, when applicable. Failure to fit the pressure reducing valve as specified will invalidate warranty of the GAH Coldstream system.

One full bore lever valve is supplied, it is recommended to install this on the supply from the accumulator.

Supply to cold taps and outlets is taken from the 'T' fitting at the base of the Accumulator.

Supply to the hot taps and outlets is from existing cylinder fittings in the traditional manner.

The cold feed to existing unvented cylinders should be fitted with a pressure regulating valve which limits the incoming pressure to 3.5 Bar, together with a non return valve and pressure relief valve (PRV). These units may be in the form of a combination valve.

Unvented cylinders must have an expansion facility, either an air gap or a suitably sized independent expansion vessel fitted.



**IMPORTANT**

**The air charge pressure of the accumulator must be adjusted when the system is empty of water - see 2-3.2**

**Both pressure reducing valves must be set to the same pressure.**

1-2.3 System with Combination Boiler

All installations must comply with relevant regulations - refer to section 2-1.

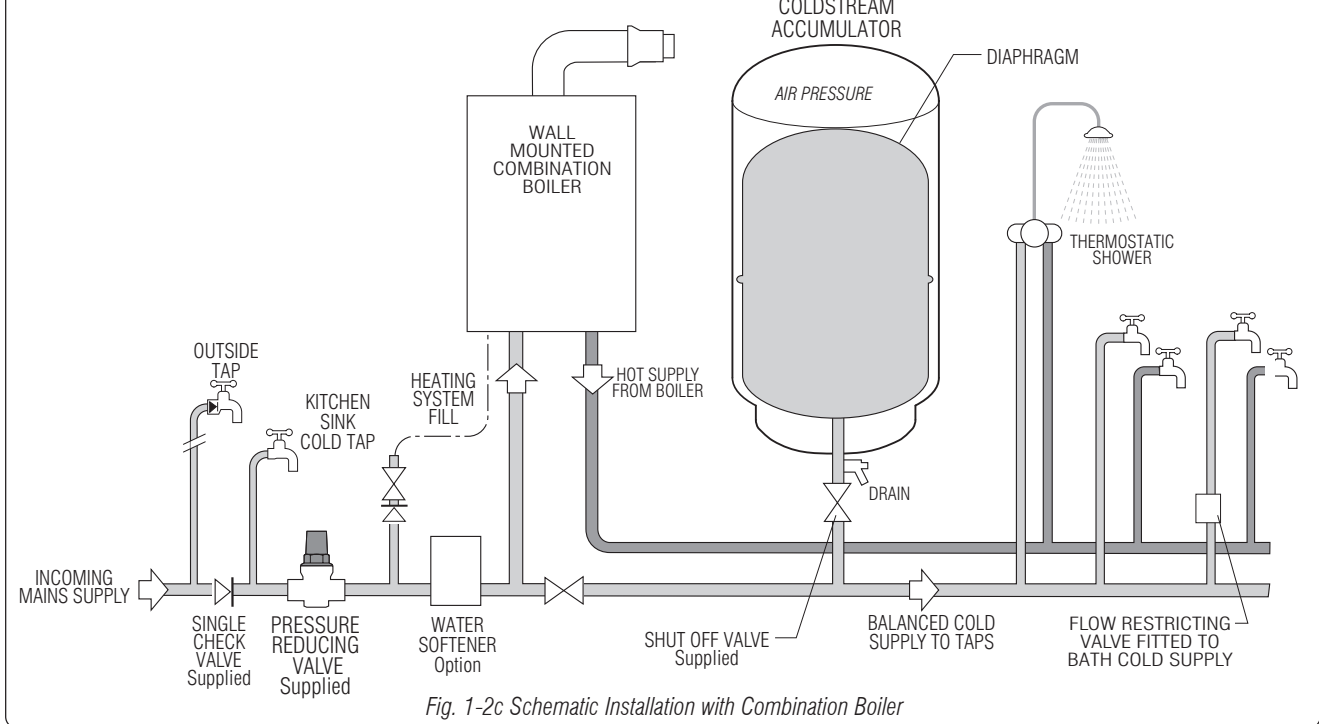

Fig. 1-2c Schematic Installation with Combination Boiler

Fig. 1-2c shows typical configuration of a GAH Coldstream system connected to a Combination boiler.

GAH Coldstream can be fitted to existing Combi systems providing all criteria as specified in this manual are met.

Where the accumulator is connected to the system is not critical, however having the connection further away from the incoming mains supply will significantly improve performance.

A Single Check Valve is supplied with the GAH Coldstream system, if one is not already fitted, this should be fitted to the mains supply prior to any connections or take offs to prevent back flow and to maintain accumulator pressure.

A Pressure Reducing Valve is supplied, this must be installed to limit the incoming main pressure. To maintain maximum main pressure to the kitchen tap and outside taps, it can be fitted following these draw offs, when applicable. Failure to fit the pressure reducing valve as specified will invalidate warranty of the GAH Coldstream system.

One full bore lever valve is supplied, it is recommended to install this on the supply from the accumulator.

Supply to cold taps, outlets and boiler are taken from the 'T' fitting at the base of the accumulator.

Supply to the hot taps and outlets are from the combination boiler.

As the cold flow to a bath from the Accumulator will be considerably more than the hot flow from the combination boiler it is recommended to fit a flow restricting valve to the bath cold supply to balance hot and cold flow from the taps.

One full bore lever valve is supplied, it is recommended to install this on the cold supply from accumulator. Other shut off valves may be required depending on installation.

Drain offs must be provided to enable the accumulator and system to be fully drained.



**IMPORTANT**

**The air charge pressure has to be adjusted before the system is filled - see 2-3.2.**

**Recommended Accumulator Size**

Boiler Type	Combi	Combi store
Accumulator Model	200-240	240-300

1-2.4 Pumped Borehole / Well Applications

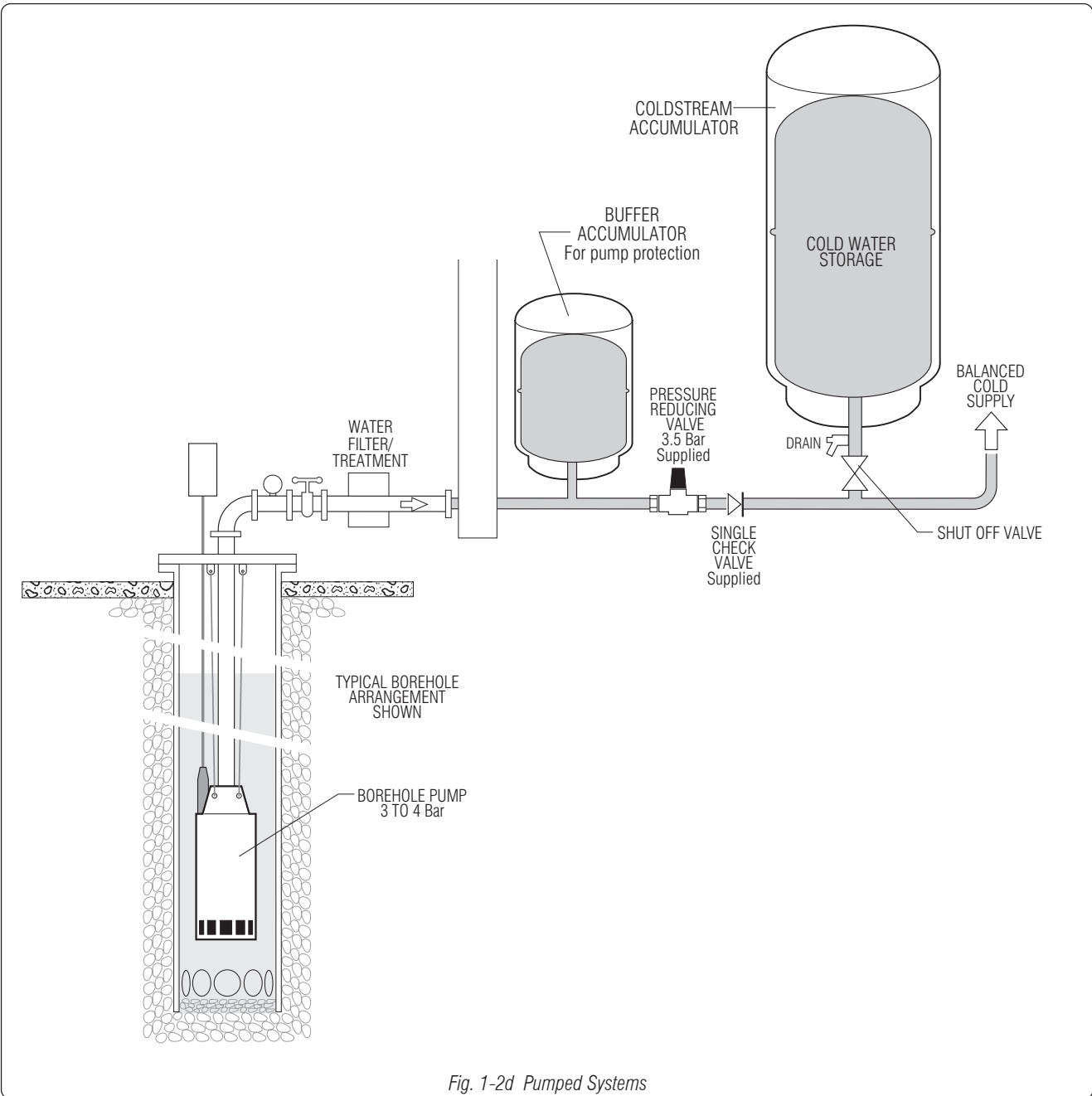

Fig. 1-2d Pumped Systems

The GAH Coldstream system can be used in applications where the cold supply is pumped from a well or borehole using a dedicated controlled submersible pump.

Existing borehole / well and pump arrangement must be fully inspected and confirmed suitable for GAH Coldstream application.

The pump should be capable of delivering a minimum of 9 litres per minute @ 1.5 to 3 Bar pressure and controlled by a pressure switch.

Fig. 1-2d shows a typical borehole application.

To protect the pump, a smaller accumulator can be connected prior to the pressure-reducing valve and single check valve, this will absorb any over pressure from the pump.

Note

For more information on boreholes and pumps consult local specialist water engineers and pump suppliers.

### 1-2.5 Sizing of System

The size of the GAH Coldstream system is determined by the capacity of the Accumulator selected and the following criteria. As the Accumulator provides increased flow rates and maintains system pressure it is important that this is of adequate size.

The Accumulator water content is up to 50 to 60% of its gross volume.

When sizing the Coldstream system close consideration should be given to:-

1. **The Accumulator should always be oversized rather than undersized.**
2. **Incoming mains supply pipe size (GAH Coldstream can be installed on a 15mm main).**
3. **Incoming mains flow and static pressure.**
4. **House type, building height and number of occupants.**
5. **Typical daily water usage and peak demands.**
6. **Number of bathrooms and total number hot and cold water outlets**
7. **Types of shower, taps and baths and the volume and pressure of water to operate them.**

*Note*  
 The Accumulator model is designated as its gross volume, the actual water content of the Accumulator is 50 to 60% of its gross volume, this is dependant on mains pressure. The lower the mains pressure, the less volume of water can be stored in the Accumulator - for water content see page 12.

The following chart is given as a guide only.

Size of Dwelling	Small Flat	Flat Smaller House	Small House	Medium House	Larger House	Large House
Usage	Kitchenette Electric Shower Basin	Kitchen 1-2 Bedrooms 1 Bath & Shower	Kitchen Cloakroom 2-3 Bedrooms 1 Bath & Shower	Kitchen, Cloakroom 4-5 Bedrooms 2 Baths & Showers	Kitchen, Cloakroom Utility Room 4-6 Bedrooms 2 Baths & Showers	Kitchens, Cloakrooms Utility Rooms Multiple Beds 4-5 Baths & Showers
Preferred Accumulator Model	100	100 200 240	200 240 300	240 300 500	300 500	500 2 x 500

*Note*  
 For Combi Boilers see 1-2.3.

GAH offer full technical assistance and design service to enable the optimum GAH Coldstream system to be configured to overcome situations where poor mains supply and pressure are considered a problem.

### 1-2.6 Scale Protection



**IMPORTANT All installations should have a scale protection device fitted and in areas known to have hard water, a water softening device is strongly recommended.**

*GAH offer a range of quality Water Softeners, for information contact GAH (HEATING PRODUCTS).*

GAH Coldstream Accumulators are not damaged by hard water or scale, however, GAH recommend and promote the use of scale prevention devices and water softeners in areas that are known to have hard water. Installed correctly they prolong the life of heating equipment and help prevent limescale formation in the pipework. Water Softeners provide the advantages of soft water, as well as preventing scale build up on taps and shower heads.

Water softeners and any mains fed system must be of adequate capacity and should be installed prior to the Accumulator with suitably sized hoses to prevent any possibility of flow reduction; for positioning refer to system diagrams in section 1-2.

### 1-2.7 Frost Protection

When planning the installation location of the Accumulator consideration must be given to the risk of frost and the use of frost protection.

The design of the Accumulator gives it a degree of frost protection enabling it to be located within the dwelling, loft space or garage without further protection.

Accumulators must have frost protection when they are installed where low temperatures could be a potential problem.

To comply with Building Regulations all necessary pipework must be suitably lagged.

**1-3 Shut Off Valves**

The GAH Coldstream installation will have a number of shut off valves, the location of these will be dependent on the installation - fig. 1-3a shows a typical layout.

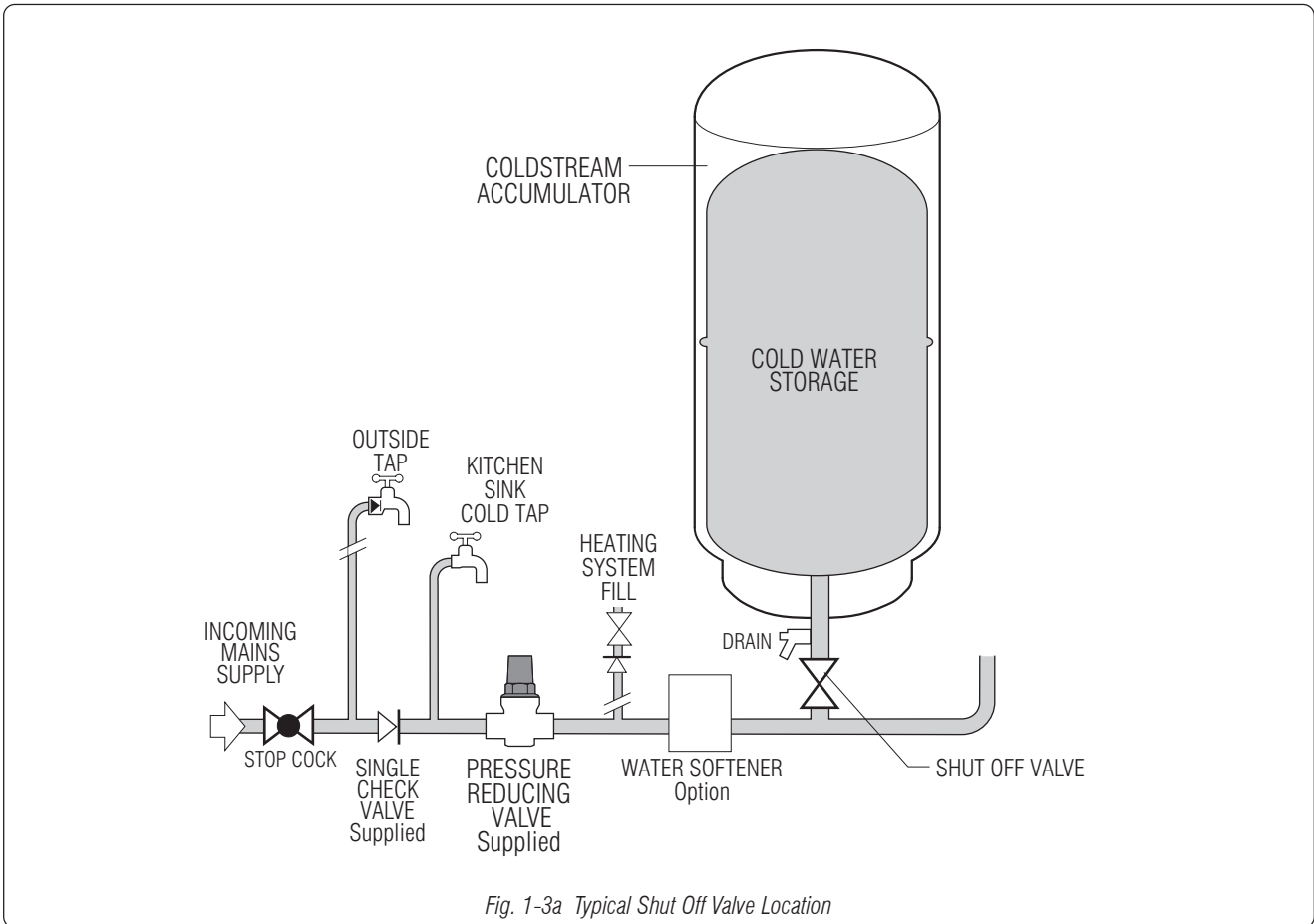

Fig. 1-3a Typical Shut Off Valve Location



**IMPORTANT Before closing ANY valve:-**  
**1. Switch OFF the Electric Immersion Heater.**  
**2. Turn OFF the Heating System.**

*Note*

*When opening the stop cock turn the valve fully open then close 1/2 turn, this prevents the valve sticking.*

**1-3.1 Stop Cock**

Normally located at the point where the mains supply enters the dwelling.  
 Shuts off the mains water supply to the dwelling.

**1-3.2 Single Check Valve**

Normally located after the Stop Cock.  
 Prevents water back-feeding to main water supply.  
 Shuts off the main water supply to the dwelling.

**1-3.3 Cold Water Shut Off Valve**

Normally located in the cold feed close to the Accumulator.  
 Shuts off the cold water to the taps.

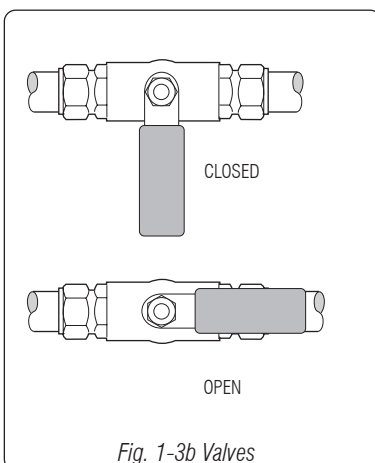
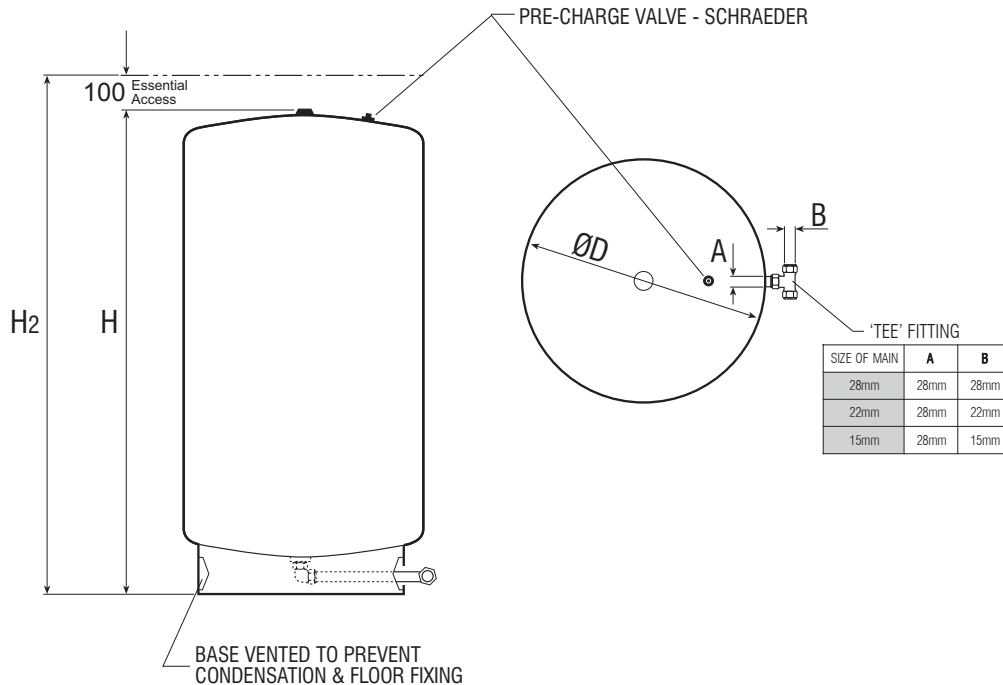

Fig. 1-3b Valves

**1-4 Specifications**

**1-4.1 Accumulator Dimensions**



Accumulator Model	Size (Gross Capacity)	*Maximum Water Content	ØD	H	H <sub>2</sub> Recommended minimum space required.	Weight Empty
100	100	up to 55 litres	410mm	890mm	990mm	16.3kg
200	170	up to 90 litres	535mm	940mm	1040mm	30.4kg
240	240	up to 130 litres	535mm	1215mm	1315mm	37.2kg
300	310	up to 160 litres	535mm	1500mm	1600mm	44.5kg
500	450	up to 240 litres	668mm	1530mm	1630mm	69.5kg

\* Water content is up to 50 to 55% of the Accumulator gross volume dependent on mains pressure.  
 Total weight = weight empty + water content @ 1kg/litre.  
 The Accumulator should always be oversized rather than undersized.

Fig. 1-4a Accumulator Dimensions

**1-4.2 Accumulator**

- NSF Standard 61, CE/PED approved
- Comprehensively tested
- Condensation reducing design
- No maintenance
- Leak free air valve cap with closed cell foam.
- Membrane Butyl for potable water  
 Patented double diaphragm  
 Complies to BS6920 WRAS approval No. 0412084
- Connection Stainless Steel
- Finish Two part polyurethane epoxy primed paint finish
- Maximum pressure 7.0 Bar
- Minimum pressure 0.5/0.8 Bar
- Factory set pressure 2 Bar

**1-4.3 Pipes**

All copper pipework must be Kite Marked BS EN1057 1996 Table X half hard copper tube.

**1-4.4 Electrics**

It is essential that all required earth continuity conductors are fitted.

**There are no electrical connections to the GAH Coldstream Accumulator.**

**1-5 Larger Systems**

For larger systems, small commercial, sports and leisure clubs, more than one Accumulator can be linked together to provide the required cold water volume. To help resolve problems of low water pressure and flow rates GAH offer a design and consultation service.

For more information consult GAH (HEATING PRODUCTS) LIMITED.

1

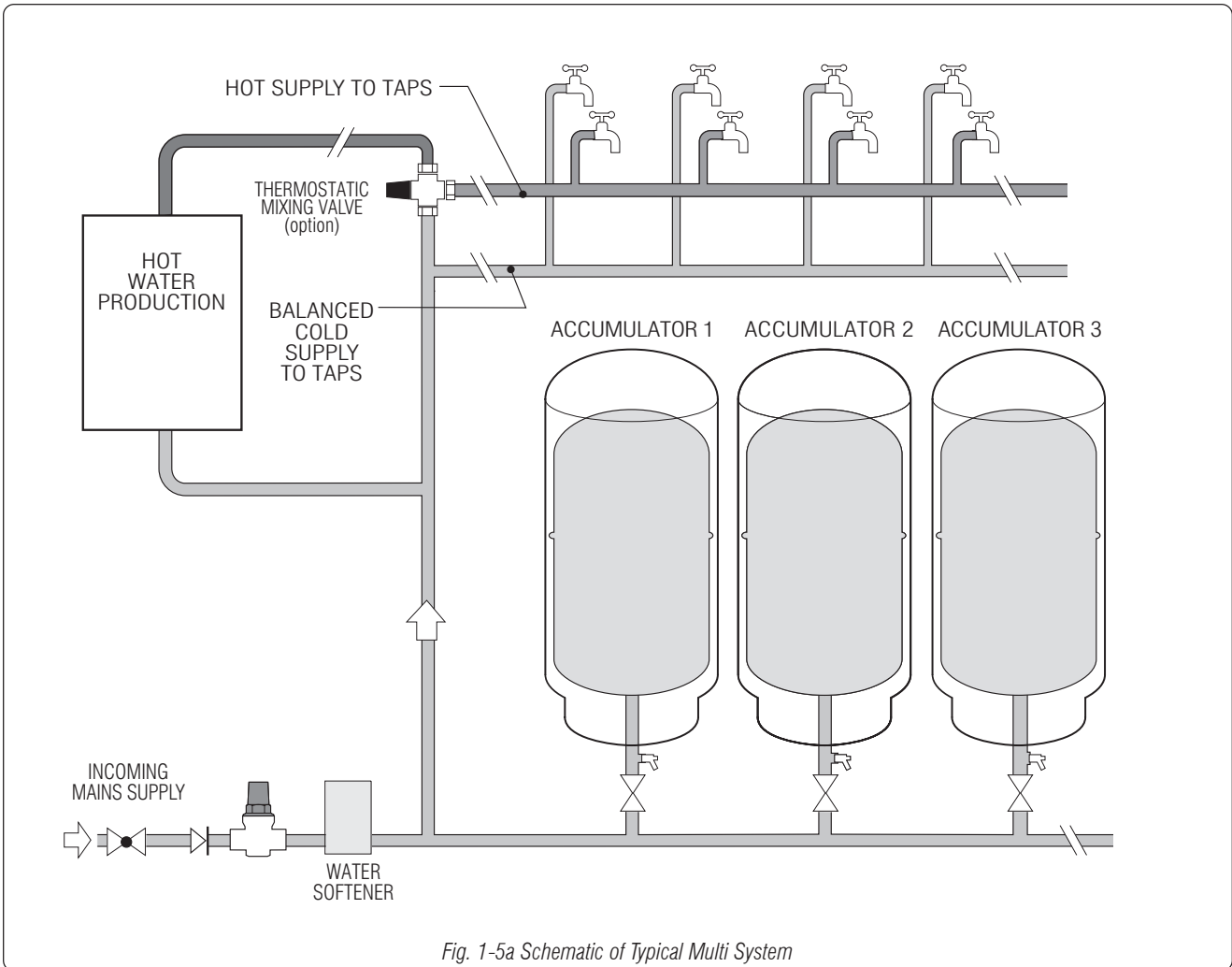

Fig. 1-5a Schematic of Typical Multi System

**2-1 Building Control**

*Note*

*In some areas it is a criminal offence to install an unvented hot water storage system without notifying the local authority, or without the relevant licence.*

To install a GAH Coldstream system the installer must be fully competent and familiar with water bye-laws and building regulations.

When installing a combination boiler or unvented cylinder the installer must be fully competent and suitably qualified. In some areas the Local Authority may require notification by means of a building notice or by the submission of full plans for the proposed installation of an unvented hot water storage system.

If there is any aspect of the GAH Coldstream system that needs clarification, please contact GAH (Heating Products) Ltd.

**2-1.1 Regulations**

The **Water Bye-laws** and **Current Building Regulations** (paying particular attention to G3 and Part L 1 & 2) and **HSE** requirements should be considered when installing an Unvented Cylinder.

**2-2 Parts Supplied**

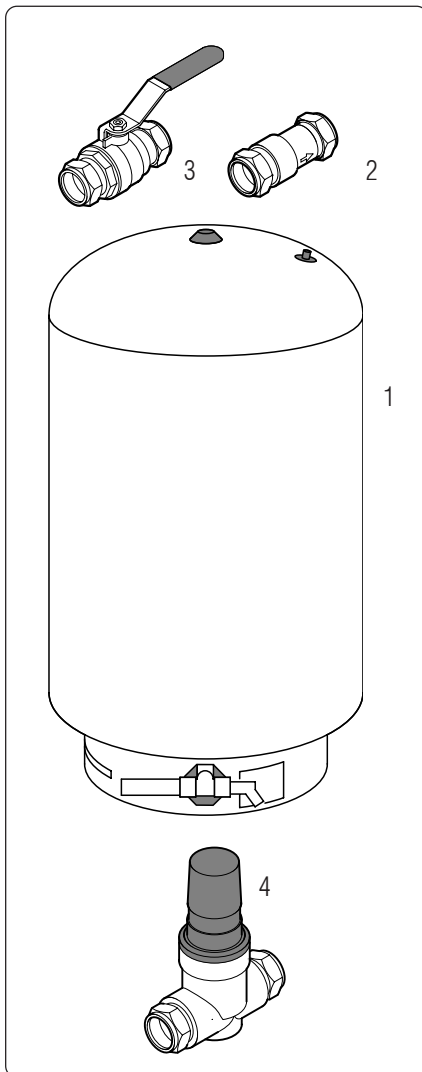

Item	Part	Qty	Notes
1	Accumulator	1	Pre-plumbed
2	Single Check Valve	1	22mm for 15mm and 22mm incoming mains 28mm for 28mm incoming mains
3	22mm Ball Valves 22mm 100, 200, 240 & 300 28mm 500	1	For domestic cold water
4	Pressure Reducing Valve	1	For incoming main

**2-3 Installation**

*Note*

*Consult the Building Regulations for safe floor loadings.*



**CAUTION**

**The main supply must be turned OFF and water drained from the Accumulator before lowering the charge pressure, failure to do so could result in damage to the diaphragm.**

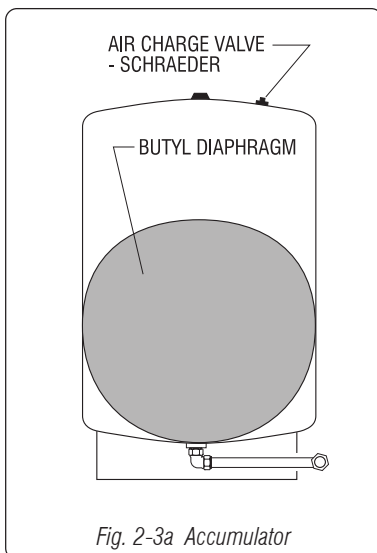

Fig. 2-3a Accumulator

**2-3.1 Accumulator**

The Accumulator may be installed at any convenient location within the dwelling, outhouse, garage, loft or basement.

In normal circumstances the Accumulator should be installed vertically. Where this is not possible Accumulators up to 240 could be installed horizontally by supporting it in a cradle (not supplied) and ensuring provision is made to make it fully drainable, please contact GAH before installation.

The floor must give adequate support to the filled Accumulator.

Accumulators must have frost protection when they are installed where low temperatures could be a potential problem - see 1-2.8.

Note that access is required to the top of the vessel for pumping the pressure and changing the membrane.

Provision must be made to enable the Accumulator to be drained when required.



**IMPORTANT**

**The Accumulator is supplied at 2 Bar pressure. It is recommended to set the pressure at 1.5 Bar below the mains pressure, minimum 0.5/0.8 Bar.**

**2-3.2 Accumulator Pressure**

Accumulators are supplied by GAH with a preset air charge of 2 Bar (28/30psi). If the incoming main has a pressure of more than 3.5 Bar a pressure reducing valve fixed at 3.5 Bar should be fitted. This will result in a pressure differential of 1.5 Bar between the system pressure and the air charge of the Accumulator.

When the incoming mains pressure is less than 3.5 Bar the pressure differential will be higher than 1.5 Bar and the Accumulator will not fill sufficiently, therefore it may be necessary to lower the Accumulator air charge pressure.

The procedure for changing the Accumulator pressure is given below, this can be done before the system has been filled. It may be done after the system has been filled and tested, providing the incoming main has been turned **OFF** and the water drained from the Accumulator. Failure to do this may result in false pressure reading and damage to the butyl diaphragm.

If mains pressure is 3.5 Bar or above changing the Accumulator charge pressure will not be necessary.

Adjusting Air Pressure

1. Record mains pressure.
2. Turn main supply OFF.
3. Turn on cold outlets to empty Accumulator.
4. Remove black cap from top of Accumulator check/confirm Accumulator pressure with pressure gauge.
5. Lower air charge so that is 1 to 1.5 Bar below mains pressure.  
Minimum Accumulator pressure is 0.5 Bar to 0.8 Bar.

**2-3.3 Expansion**

The GAH Coldstream system alone does not require any expansion requirements.

Any new or existing unvented cylinders or mains fed appliances must have satisfactory arrangements for expansion and discharge as applicable and in accordance with the manufacturers instructions and G3 building regulations.

### 2-3.4 Pipework

When all pipework has been installed, disconnect from the GAH Coldstream Accumulator and flush all pipework thoroughly.

When connecting to existing pipework remove all unwanted components, create new pipe runs then flush thoroughly before connecting to the GAH Coldstream Accumulator.

### 2-3.5 GAH Coldstream Components

All GAH Coldstream components and pipework are checked at the factory prior to dispatch, however always check the connections for leaks on commissioning as transportation and installation can cause joints to move.

### 3-1 Commissioning Checks

It is the responsibility of the installer to ensure that the GAH Coldstream System is properly commissioned.



**IMPORTANT**

Should the commissioning not be carried out, then the manufacturers two year guarantee will become null and void.

The Guarantee Form **MUST** be completed and returned to GAH (HEATING PRODUCTS) in the prepaid envelope provided.

#### 3-1.1 Commissioning Procedure

1. Check Accumulator pressure is 1.5 Bar below the mains pressure.- see 2-3.2.
2. Check all pipe connections are tight and that no joints have been left unsoldered.
3. Check ALL drain cocks are closed.
4. Check the required earth continuity conductors have been fitted where applicable.
5. If fitted, check Scale Protection device or Water Softener has been fitted according to manufacturers instructions.
6. Open all shut off valves.
7. Turn on Mains Stop Cock and allow the system to fill.
8. Open all domestic taps in turn to purge air.
9. Check system for leaks.

### 3-2 Handing Over

Having filled in the Guarantee Form, this should be sent to GAH (HEATING PRODUCTS) LIMITED. The Installer should next re-check the system and ensure it is completely satisfactory before demonstrating to the householder.

This manual and any supplements must be left with the householder together with a copy of the completed Guarantee Form.

### 3-3 Routine Inspection

The GAH Coldstream system should have a routine inspection every 12 months, this is best carried out as part of the unvented system or combination boiler service.



**IMPORTANT Always turn off the heating system before working on the GAH Coldstream System.**



**IMPORTANT**

**Also carry out any service requirements of specific components as specified by the manufacturers instructions.**

#### 3-3.1 Inspection

1. Confirm with customer, service history.
2. Visually inspect Accumulator for damage, metal failure and signs of leaks.
3. Visually inspect all Coldstream pipework for damage, metal failure and signs of leaks.
4. Record mains pressure and system pressure.
5. Turn the Heating System OFF.
6. Close the Stop Cock.
7. Open the cold taps, attach a hose to the Accumulator drain cock and empty the system.
8. Check the pressure of the Accumulator, this should be 1.5 Bar below the mains pressure with a minimum of 0.5/0.8 Bar.
9. Close all drain cocks and refill system.
10. Switch on the heating system.
11. Check for leaks.
12. Record details of service.

*Note*

*If heavy scaling is evident then descaling the system is recommended. Ensure system is fully flushed following descaling.*

**4-1 Fault Finding - also see [www.gah.co.uk](http://www.gah.co.uk)**

No COLD Water Supply

1. Check the mains supply has not been interrupted from the main.
2. Check the stop cock and all valves on the mains supply are correctly installed.
3. Check the stop cock and any valves on the mains supply are fully open.

Reduced Pressure

1. Check mains supply has not been interrupted.
2. If fitted, check the combination valve line strainer is not blocked - clean if required.
3. Check line strainers and any other fittings are not blocked - clean if required.
4. Check Accumulator air pressure and performance.

Water Leaks

Please consult your installer.

In the unfortunate event of a water leak from the GAH Coldstream Accumulator, turn off the mains water supply to the house via the stop cock. Make allowance to store some cold water for necessities. Open both cold and hot taps to drain the cylinders of water thus preventing any further leaks and consult your installer.

Poor Flow Rate at Taps

1. Check all isolation valves are fully open.
2. Check Accumulator charge pressure is not too high - refer to 2-3.1.
3. Check pipework from Accumulator is of adequate size.
4. Check line strainer in pressure reducing valve when applicable.

Good volume which falls away too quickly

1. Check Accumulator charge pressure is not set too high. Reset pressure as section 2-3.2.
2. Check Accumulator is correct size for application.

Cold water discoloured

1. Check to make sure there is air in the Accumulator via the Schrader valve. If air is not present, suspect faulty Accumulator, consult GAH (HEATING PRODUCTS).
2. Check mains supply - it may have been interrupted.
3. Check water softener (when fitted) is operating correctly.

**4-4.1 Accumulator Check Procedure**

If the Accumulator has no air or is suspect of diaphragm failure, carry out the following procedure.

1. Turn Off mains supply.
2. Turn on an Accumulator fed cold tap - i.e. bath tap.
3. Wait until the water stops flowing then check Accumulator.
4. Check Accumulator air charge, if there is no air present this indicates either:-  
Possible valve failure - check and replace valve.  
Or possible diaphragm failure - consult GAH.
5. Check Accumulator for water content, under normal circumstances it should be empty, if it is still full consult GAH.





heating products

---

GAH (Heating Products) Ltd.

Building 846,  
Bentwaters Parks,  
Rendlesham,  
Woodbridge,  
Suffolk IP12 2TW

---

[www.gah.co.uk](http://www.gah.co.uk)

---

Tel: 01394 421160

Fax: 01394 421170

---

email: [mail@gah.co.uk](mailto:mail@gah.co.uk)

---